



Regular models

14.12012	0,01	30	58	with	1	0 ÷ 50 ÷ 100	≤ 2,2
14.12013	0,01	50	58	with	1	0 ÷ 50 ÷ 100	≤ 2,5
14.12014	0,01	100	82	with	1	0 ÷ 50 ÷ 100	≤ 3,2



See table opposite



See table opposite



3 mm dia. ball tip already mounted



Cardboard box



Identification number



Inspection report with a declaration of conformity

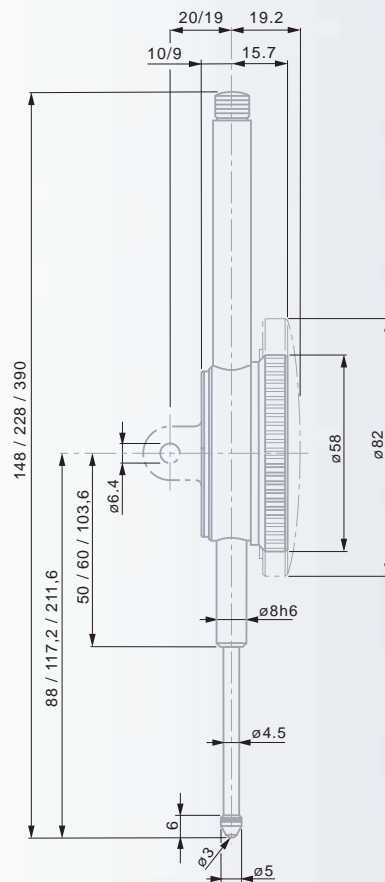

Accuracy



mm 30 50 100



Deviation span
Total deviation span

µm 20 25 30
µm 25 30 35



Repeatability limit

µm 3 3 3



Max. hysteresis

µm 5 5 8